

AVERY DENNISON MARKETING SPECIFICATION

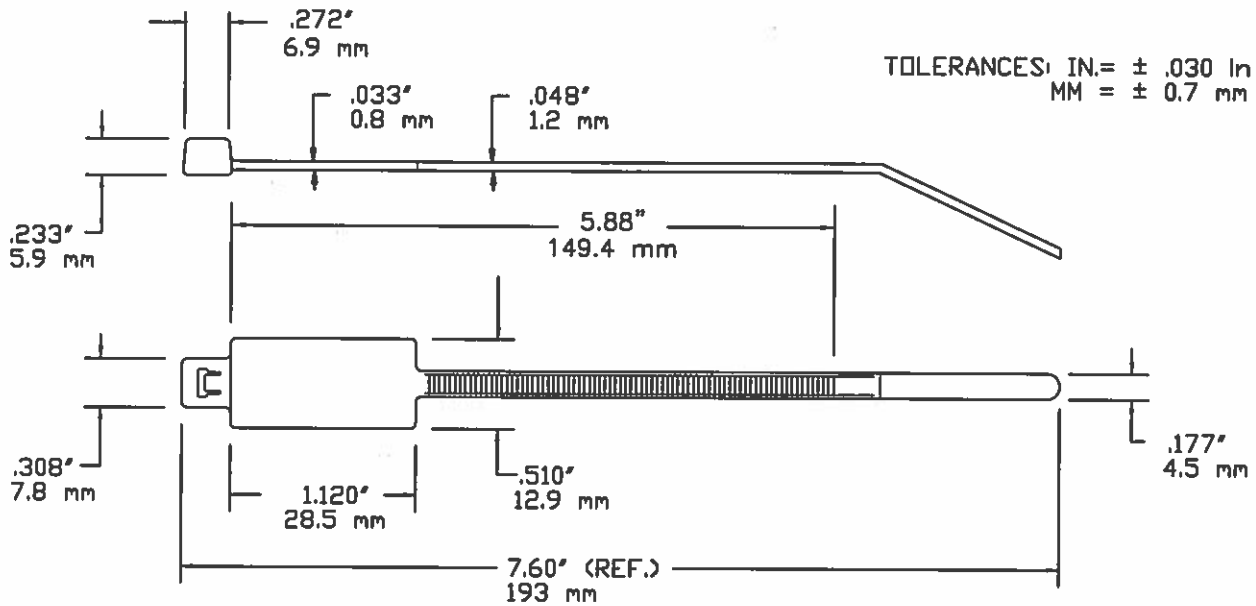

NOT TO SCALE

| | |
|--------------------------|--|
| LOOPED TENSILE STRENGTH: | 50 Lbsf. / 220N MINIMUM PER MIL-S-23190. |
| MILITARY STANDARD: | MS-3368-1-9A |
| MATERIAL: | NYLON 6/6 |
| WEIGHT: | .04590 oz. / 1.35 grams |
| BUNDLE DIAMETER: | ∅0.375"/9.53mm to 1.75"/44.0mm |
| MIN. INSTALLATION TEMP: | 32°F (0°C) |
| OPERATING TEMPERATURE: | -40°F(-40°C) to 185°F(85°C) |
| APPLICATION TOOL: | TOOL, HAND ADJUSTABLE, FOR PLASTIC TIE DOWN STRAP. AVERY DENNISON PART NUMBER 12001. |
| TOOL TENSION SETTING: | 6-8 |
| PACKAGED IN: | 100 PACKS IN SEALED BAGS |

PLENUM RATED AND HAS A FLAMMABILITY RATING OF V-2
UL APPLICATIONS REQUIRE USE WITHIN ENCLOSURES.



FASTENER DIVISION
FITCHBURG, MA 01420 U.S.A.
TEL 1-800-225-5913
MA 978-353-8157

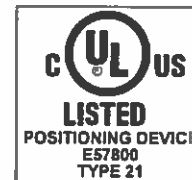

DESCRIPTION:

7.5" CABLE TIE, STANDARD IDENTIFICATION - NATURAL

APPROVAL: Q.A.:

Linda Boyle 4-1-2016

STOCK NO.

08419-0

REV

B

Mouser Electronics

Authorized Distributor

Click to View Pricing, Inventory, Delivery & Lifecycle Information:

[Avery Dennison:](#)

[08419-0](#)